

REFERENCE:

PERFORMANCE REQUIREMENTS AT DRY AS MOLDED:

1. FIR TREE PUSH IN FORCE: 10 lbs MAX IN AN OVAL HOLE THAT IS 8mm X 15mm AND A SHEET METAL THICKNESS OF 1.8mm.
2. FIR TREE PULL OUT FORCE: 40 lbs MIN IN AN OVAL HOLE THAT IS 8mm X 15mm AND A SHEET METAL THICKNESS OF 1.8mm.
3. SHEET METAL THICKNESS RANGE: 0.60mm - 6.50mm

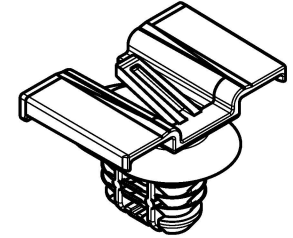

Isometric view
Scale: 1:1

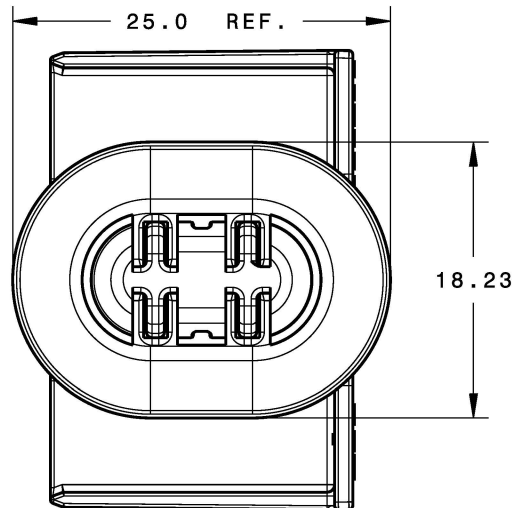
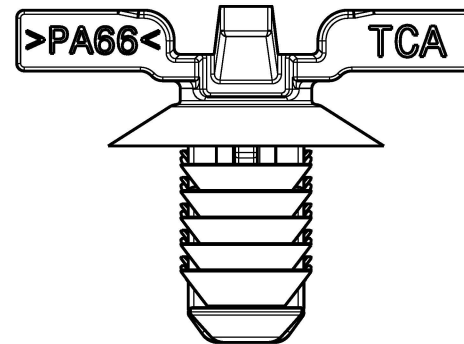
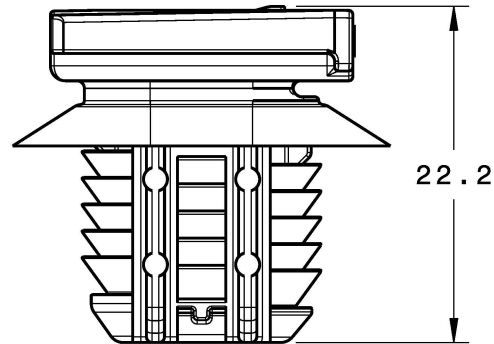

HellermannTyton®

ALL PROPRIETARY RIGHTS IN THE SUBJECT MATTER SHOWN ON THIS DRAWING ARE EXCLUSIVE PROPERTY OF HELLERMANNTYTON

name	date	city, state
SJA	4/17/12	MENOMONEE FALLS, WI

REVISIONS

level	01
by	SJA
date	4/17/12
ECN #	012107
part level	A

DIMENSIONS

TOOL PREPARANCES

.XXXX = ± 0.25
.XXX = ± 0.5
.XX = ± 1.0
.X = ± 2.0
∠ = ± 1.0

unless otherwise specified

units millimeters

PART

number	CC12	phase	PRODUCTION
name 8 X 15mm OVAL HOLE CONNECTOR CLIP			
material PA66HIRHS COLOR: BLACK			

DRAWING

FORMAT	AH	CAD	CATIA V5	SCALE	2:1
VERSION	J	A- SIZE (landscape)_N01		previous drawing number	
drawn	S. ADAMS	checked	K. VAN HULST	approved	
	3/16/12		6/20/12		
type	CUSTOMER		sheet 1 of 1		
number	12-0306-011-CSU				